



**FRESENIUS
MEDICAL CARE**

**2008K@HOME™
HEMODIALYSIS SYSTEM
TECHNICIAN'S
MANUAL**

Part Number 490078 Rev. E

**Fresenius Medical Care North America
920 Winter St.
Waltham, MA 02451**

**Manufactured by:
Fresenius USA, Inc.
4040 Nelson Avenue
Concord, CA 94520**

<http://www.fmcna.com>

Copyright © 2005 - 2017 Fresenius Medical Care, All Rights Reserved

2008K@home Technician's Manual

© Copyright 2005 - 2017 Fresenius Medical Care, Inc.—All Rights Reserved

This document contains proprietary and confidential information of Fresenius USA, Inc. d/b/a Fresenius Medical Care North America and its affiliates (“Fresenius Medical Care”). The contents of this document may not be disclosed to third parties, copied, or duplicated in any form, in whole or in part, without the prior written permission of Fresenius Medical Care.

Fresenius Medical Care, the triangle logo, 2008, Diasafe and bibag are trademarks of Fresenius Medical Care Holdings, Inc., or its affiliated companies. All other trademarks are the property of their respective owners.

Any questions, contact Technical Support at 800-227-2572

TABLE OF CONTENTS

- I SPECIFICATIONS
- II HYDRAULIC DESCRIPTION
- III ELECTRONIC CIRCUIT DESCRIPTION
- IV MODULE DESCRIPTION

ADDITIONAL DOCUMENTATION*:

2008K@HOME USER'S GUIDE (P/N 490180)

2008K@HOME CALIBRATION PROCEDURES (P/N 507664)

2008K@HOME PREVENTIVE MAINTENANCE
PROCEDURES BOOKLET (P/N 507665)

2008K@HOME HYDRAULIC FLOW DIAGRAMS (P/N 700074)

2008K@HOME ELECTRONIC BLOCK DIAGRAMS (P/N 290253)

2008K@HOME DEBUG SCREENS BOOKLET (P/N 490084)

biBag® V2.0 TECHNICIAN'S MANUAL (P/N 490188)

* The latest revision of the additional documentation can be found at the following web location:



<https://fmcna.com/product-support-documentation/>

SECTION I - SPECIFICATIONS

2008K@HOME™ HEMODIALYSIS MACHINE

Refer to the “Machine Specifications” section of the 2008K@home User’s Guide (P/N 490180)* for the complete list of machine specifications for the 2008K@home Hemodialysis machine.

Conventions

Symbol	Description
	<p>Warning! A statement that identifies conditions or actions that could result in personal injury or loss of life. Warnings found in this manual outside of this section are designated with the warning symbol.</p>
	<p>Note: Notes are advisory comments or recommendations regarding practices or procedures.</p>

* The latest revision of documentation can be found at the following web location:

<https://fmcna.com/product-support-documentation/>

PRODUCT IMPROVEMENT POLICY

The 2008K@home Hemodialysis machine was designed and built to comply with the product specifications outlined in the 2008K@home User's Guide (P/N 490180). It is the intention of Fresenius Medical Care North America to improve products continuously, a process which may result in modifications to specifications or equipment produced in the future. Such product improvements shall not incur any obligation to make similar changes or improvements to equipment previously produced. These changes or improvements may or may not be applicable or usable with previously produced equipment. Where possible, improvements will be made available at reasonable prices. Any such improvements shall not be construed as corrections of any perceived deficiency.

In order to properly calibrate and maintain the 2008K@home Hemodialysis machine, the documentation being used must be up to date. The current revision of a document can be obtained from the Fresenius Medical Care Website at:

<https://fmcna.com/product-support-documentation/>

SECTION II – HYDRAULIC DESCRIPTION

DESCRIPTION OF THE HYDRAULIC COMPONENTS

All valves and motors are supplied with 24V DC; the heater is supplied with 120V AC 60Hz; thermistors, float switch, blood leak detector, pressure sensors and reed switches with 12V DC; conductivity cell and level sensor with 12V AC at high frequencies;

Inlet filter screen

Prevents the 2008K@home Hemodialysis machine components from being obstructed (mounted in the inlet water line).

Water inlet regulator

Limits the inlet water pressure.

Balancing chamber

The most important component for volumetric dialysate balancing; two spherical chambers (30ml each); 8 solenoid valves; two membranes reliable and proven hydraulic component from A2008C/D/E/H series; guarantees accurate fluid balancing.

Hydroblock/Hydrochamber

Consists of a heater including valve “39” and an orifice to provide sufficient volume to deaerate the water; separates the air from the water and provides mounting for the loading pressure valve; control NTC 2 (temperature sensor for temperature control circuit);

Function: warming water; provides air gap and a level sensor to maintain the water level.

Monitoring NTC 3

Function: independent temperature sensor for temperature monitoring.

Flow indicator

Optical flow indication and gross flow measurement.

Dialyzer valves V24, V25, and bypass valve V26

Bypasses (V24 closed, V25 and V26 open) the dialyzer and prevents exposure of the patient to improper dialyzing fluid (temperature or conductivity alarm); the dialyzer can be isolated (V24 and V25 closed, V26 open; i.e. for online pressure holding test or resetting a hardware TMP alarm (i.e. adjusting TMP). For adjusting TMP, V24 closed, V25 and V26 open to serve as bypass.

Dialysate line safety interlock

2 switches for dialysate lines;

1 switch for bypass when shunt cover is open;

provides additional safety against inadvertently rinsing or disinfection;

defines dialyzer emptying program.

Dialyzer filter

Prevents hydraulic components from being obstructed; mounted outside 2008K@home Hemodialysis machine; easy to service.

Dialysate pressure transducer

Pressure transducer for dialysate pressure measurement; used as a sensor for the pressure holding test. It is also used to switch the balancing chamber in rinse mode.

Blood leak detector

Color sensitive blood leak detector (temperature compensated), is able to distinguish between opaque layers in the cell and real presence of blood in the dialyzing fluid.

Secondary air separation

Prevents air from entering the balancing chamber assuring precise weight removal; device contains fluid level detector, air separation volume and valve V43.

Mixing chamber

A cylindrical chamber that swirls the proportioned dialysate solution, which provides for a complete mixing prior to entering the balancing chamber.

Chamber Full Switch

Pressure transducer that senses pressure peak to switch the balance chamber.

Flow pump

DC motor driven gear pump;
Function: filling of the balancing chamber, spent side.

Deaeration pump

Provides deaeration and loading pressure.

Heat exchanger

Preheats inlet water by using the thermal energy in the spent dialysate.

Conductivity cell

Measures conductivity pre dialyzer.

UF pump

Responsible for fluid removal

Acid pump

Delivers acid proportioned by the microprocessor according to settings in the Dialysate Composition Screen.

Bicarbonate pump

Delivers bicarbonate proportioned by the microprocessor according to settings in the Dialysate Composition Screen.

Recirculation valve V29

Allows fluid to the drain to be diverted into the hydroblock/hydrochamber; used in heat disinfect to heat up faster and to conserve energy.

HYDRAULIC CONNECTION PANEL

TO DIALYZER - tubing to dialyzer (blue dialyzer quick connector)

FROM DIALYZER - tubing from dialyzer (red dialyzer quick connector)

WATER INLET - hose for water inlet

TO DRAIN - outlet hose to drain

GROUND - fixing screw for potential equalization

HYDRAULIC OPERATION

1. Time constants

The overlap time (delay time) of the balancing chamber valves is always 50 ms. This time is included in the switching time of the balance chamber (i.e., switching time is 6.00 seconds means a 5.95 second fill time plus a 50 ms delay time).

Time constants of the balance chamber.

- Flow rate 100 ml/min $t = 18.0 \text{ s} \pm 10\%$
- Flow rate 200 ml/min $t = 9.0 \text{ s} \pm 10\%$
- Flow rate 300 ml/min $t = 6.0 \text{ s} \pm 10\%$
- Flow rate 400 ml/min $t = 4.5 \text{ s} \pm 10\%$
- Flow rate 500 ml/min $t = 3.6 \text{ s} \pm 10\%$
- Flow rate 600 ml/min $t = 3.0 \text{ s} \pm 10\%$
- Flow rate 700 ml/min $t = 2.57 \text{ s} \pm 10\%$
- Flow rate 800 ml/min $t = 2.25 \text{ s} \pm 10\%$

2. Rinse

Rinse can only be started if the acid and bicarbonate connectors are in their rinse ports, the dialyzer couplings are connected to the shunt, the shunt door is closed and there is no blood sensed.

During rinse the following occurs:

- The UF pump runs at 4000 ml/h
- V24 and V25 alternately open and close with the opening of V26 every balancing chamber cycle.
- V43 opens 6 out of 31 balancing chamber cycles.
- V29 opens 3 out of 31 balancing chamber cycles.
- The acid and bicarbonate pump stroke every balancing chamber cycle.

This pattern assures that all of the various parts of the hydraulics get adequately rinsed.

The rinse program lasts until it is stopped by the timer counting to 0 or by the operator. The remaining time on rinse is displayed on the screen. If the remaining time is zero, the machine stops the flow pump and displays a message “Press CONFIRM to exit” in the status box.



Note: The rinse time is selectable by the user in the Default Settings of Service Mode.

3. Mandatory Rinse

A Mandatory Rinse has to always be performed after or interrupted Chemical Disinfection and/or Acid Clean. The user is informed by a message in the status box. The only difference between Mandatory Rinse and a regular Rinse program is that the Mandatory Rinse has to run for a predefined time and cannot be terminated.

If the machine is turned off or the acid or bicarbonate connectors are pulled during Mandatory Rinse before the needed time is over, the machine comes up with Mandatory Rinse again after power on.

Mandatory Rinse can only be started if the acid and bicarbonate connectors are in their rinse ports, the dialyzer couplings are connected to the shunt, the shunt door is closed and there is no blood sensed.

During a Mandatory Rinse, the remaining time are displayed. If the remaining time is zero, the machine stops and displays a message “Press CONFIRM to exit” in the status box.



Note: The Rinse time, selectable by the user in the Default Settings of Service Mode, is used to time the Mandatory Rinse. For Diasafe, if the Rinse time is greater than 15 minutes, otherwise it displays 15 minutes.

4. Chemical Disinfection/Rinse

Chemical Disinfection/Rinse can only be started if the acid and bicarbonate connectors are in their rinse ports, the dialyzer couplings are connected to the shunt, the shunt door is closed and there is no blood sensed. When Acid Cleaning is started, the lines are rinsed and then prompts to attach the acid and bicarbonate connectors to jug(s) containing an acid cleaner. The Chemical Disinfection/Rinse procedure is followed immediately by a Post Rinse.

If the machine is turned off or the acid or bicarbonate connectors are pulled during Chemical Disinfection/Rinse before the needed time was over, the machine comes up with Mandatory Rinse after power on. During pulling acid, returning acid to its rinse port.

If the machine has performed any program other than rinse or heat disinfect before, the Chemical Disinfection/Rinse program always starts with a pre-rinse for 7 minutes (or 10 minutes if Diasafe Filter is selected in Hardware Options of Service Mode) to rinse out concentrate or any disinfectant. The pre-rinse time is displayed on the screen.

After pre-rinse, the machine pulls in 120ml of disinfectant, the timer starts decrementing until it reaches 0 and the cycle is finished. The pre-rinse, the time remaining, and the post-rinse times are displayed on the screen. If the remaining time is zero, the machine prompts to connect the acid connector into its rinse port and a Post Rinse will begin.

During the Post Rinse the remaining time is displayed. If the remaining time is zero, the machine stops and displays a message “Press CONFIRM to exit” in the status box.



Note: The Chemical Disinfection/Rinse time is selectable by the user in the Default Settings of Service Mode.

5. Acid Clean

Acid Cleaning can only be started if the acid and bicarbonate connectors are in their respective rinse ports, the dialyzer couplings are connected to the shunt, the shunt door is closed and there is no blood sensed. When Acid Cleaning is started, the lines are rinsed and then prompts to attach the acid and bicarbonate connectors to jug(s) containing an acid cleaner.

When the program is complete, if the machine is turned off or the acid or bicarbonate connectors are inserted into their rinse ports during an Acid Cleaning before the needed time was over, the machine comes up with Mandatory Rinse after power on.

If the remaining time is zero the machine stops and prompts to connect the acid and bicarbonate connectors into their respective rinse ports. The machine will display the message “Press CONFIRM to exit” in the status box. A Mandatory Rinse must be performed prior to using the machine.



Note: The Acid Cleaning time is selectable by the user in the Default Settings of Service Mode.

6. Heat disinfect

Heat disinfect can only be started if the acid and bicarbonate connectors are in their rinse ports, the dialyzer couplings are connected to the shunt and the shunt door is closed and blood is not sensed.

If the machine has performed any program other than rinse or heat disinfect before, the heat disinfect program always starts with a pre-rinse for 7 minutes (or 20 minutes if Ext. Pre-Rinse is selected in Default Setting of Service Mode or 10 minutes if Diasafe Filter is selected in Hardware Options of Service Mode) to rinse out concentrate or any disinfectant. The Pre-Rinse time is displayed on the screen.

After Pre-Rinse, the machine starts running in recirculation mode (V29 open and V30 closed). When the water temperature reaches 80°C, the timer starts decrementing until it reaches 0 and the cycle is finishes. The Pre-Rinse time and the time remaining are displayed on the screen. If the predefined time has elapsed, the machine turns off all pumps and valves and displays the message “Press CONFIRM to exit” in the status box or, if set, the machine will power off when heat disinfection finishes.



Note: The heat disinfection time is selectable by the user in the Default Settings of Service Mode.

7. Flow off

After the flow has been turned off, the heater is turned off and the deaeration pump will turn off after one minute.

8. No program mode (Select Program screen)

In “no program state” everything is off except for the deaeration pump and V25, V26, V30, V31, V32, V33 and V34 are on. Alarms are not active or displayed except for blood pressure alarms. If blood is sensed there will be an audible alarm and a message in the display. The heater is disabled.

9. Filling Program

The filling program is a special hydraulic program that runs when air is detected at level sensor #6. The flow rate is reduced and valve 43 is open depending on dialysate pressure so that when the pressure is high enough, air in the air separation chamber is sent down the drain. Unlike normal balance chamber operation, the spent side of the balance chamber is not opened to the drain. Instead, all dialysate put into the fresh side of the balance chamber is used to push air and any additional dialysate down the drain through valve 43. The level sensor #6 (Air Sensor in Air Separation Chamber) is only checked at the end of the cycle. If there is still air in the air separation chamber, the next cycle is performed. If not, the machine will go on with dialysis. If the filling program occurs and there are no water alarms, valves 24 and 25 are open and valve 26 is closed during the filling program. UF is stopped during the filling program. If the filling program runs for more than 60 seconds with blood sensed, a permanent fill alarm will occur and the message “Fill Program Alarm” is displayed in the status box.

10. Flow alarm

Flow alarm will occur if:

- a. The float switch opens valve 41, and the water level is not up within the approximately 6 seconds, all balance chamber valves shut off, heater is off until the sensor detects water (“No Water” message is displayed).
- b. If the float switch does not detect a low level within 2.5 seconds after the balance chamber did cycle (“Flow Inlet Error” message is displayed). Exception is recirculation. Heater off
- c. The CFS (chamber full switch) does not switch the balance chamber for 10 seconds. Exception is flow off and no program state. Heater off (“Flow Error” is displayed).
- d. The CFS switches the chamber faster than 1.8 seconds. Heater off (“High Flow Error” is displayed).

DIALYSATE CIRCUIT

In the dialysate compartment, water and concentrate are mixed at the set ratio and then deaerated and heated to desired temperature (range 35-39°C).

1. Water Inlet

Allowable water pressure: 20 to 105 PSI. Water temperature must be a minimum of 10°C, and a maximum of 25°C. The water must meet AAMI (Association for the Advancement of Medical Instrumentation) standards for water for dialysis. Periodic maintenance and disinfection procedures are required to maintain the water quality. Refer to the “Machine Specifications” section of the 2008K@home User’s Guide (P/N 490180) for the water quality specifications.

2. Deaeration

The dialysate is deaerated by negative pressure created by the deaeration pump.

3. Heating

The 1300 watt heater adjusts the dialysate to the desired temperature. There is a control which allows adjustment of the dialysate temperature between 35 and 39 °C. A heat exchanger is used to recover the heat from the drain fluid.

4. Dialysate Balancing Chamber

The balance chambers assure that equal amounts of dialysate enter and exit the dialyzer. The UF membrane pump withdraws extra fluid at a set rate. This causes a UF pressure or transmembrane pressure (TMP), dependent on the dialyzer and the UF rate. The fluid withdrawn by the membrane pump flows from the blood as ultrafiltrate. The function is described on the following pages.

5. Proportional Mixing System

The balance chamber is also part of the mixing system. After each filling of a balance chamber, the acid pump makes one stroke supplying the correct amount of acid into the hydraulic mixing chamber. If bicarbonate is employed, the bicarbonate pump will make one or two strokes depending on the bicarbonate level selected and the type of acid used.

Fig III-1a: Diagram of Dialysate Chamber System

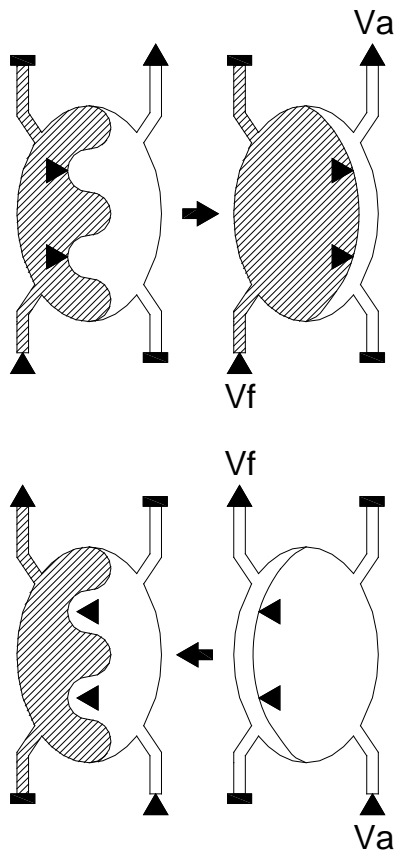

First phase of cycle:

The liquid entering the left hand compartment expels an equal quantity from the right hand compartment via the diaphragm. At maximum deflection of the diaphragm, the expelled volume V_a is equal to the volume of the chamber.

Second phase of cycle:

After the diaphragm cavity flow directions have been reversed, the liquid entering the right hand compartment expels the same quantity from the left hand compartment via the diaphragm. At maximum deflection of the diaphragm, the expelled volume V_f is equal to the volume in the chamber.

In the two described cases the volume expelled from either compartment equals exactly the total volume of the chamber:

$$V_f = \text{volume of chamber} = V_a$$

$$V_f = V_a$$

The use of only one chamber would produce an irregular flow. In order to obtain a continuous flow of dialysate, a further chamber is switched parallel to the first chamber and operated at an inverse sequence.

Figure III-1b: Dialysate Balancing Chamber (Phases of One Chamber)

It is insured that the same amount of dialysate is always fed to the dialyzer and discharged by the dialyzer.

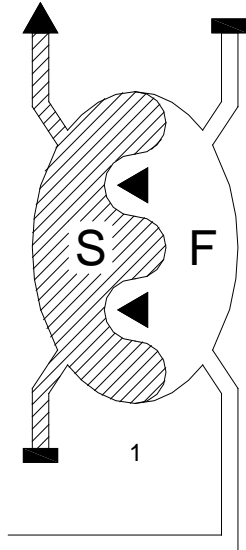

Phase 1:

The right-hand side of the balance chamber fills with fresh dialysate. The resulting pressure on the membrane forces the spent dialysate solution out.

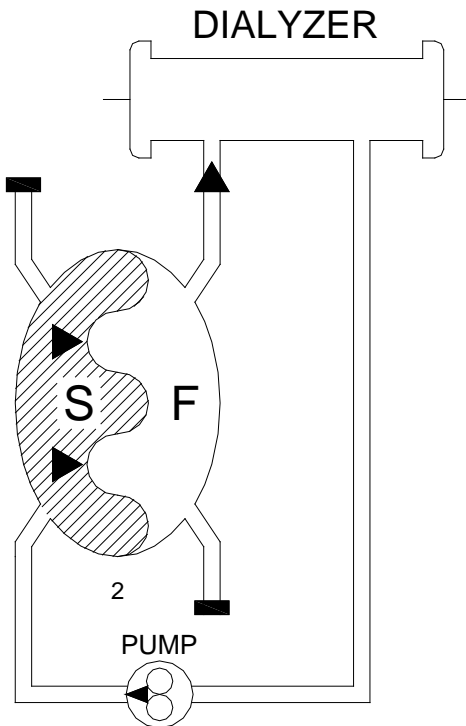

Phase 2:

The left hand compartment fills with used dialysate. The fresh dialysate is pressed to the dialyzer.

With just one balance chamber, dialysate would be unable to flow constantly through the dialyzer, as the two phases have to succeed one another. Therefore, the system has two balance chambers that work alternately.

Figure III-1c: Dialysate Balancing Chamber (Phases of Two Chambers)

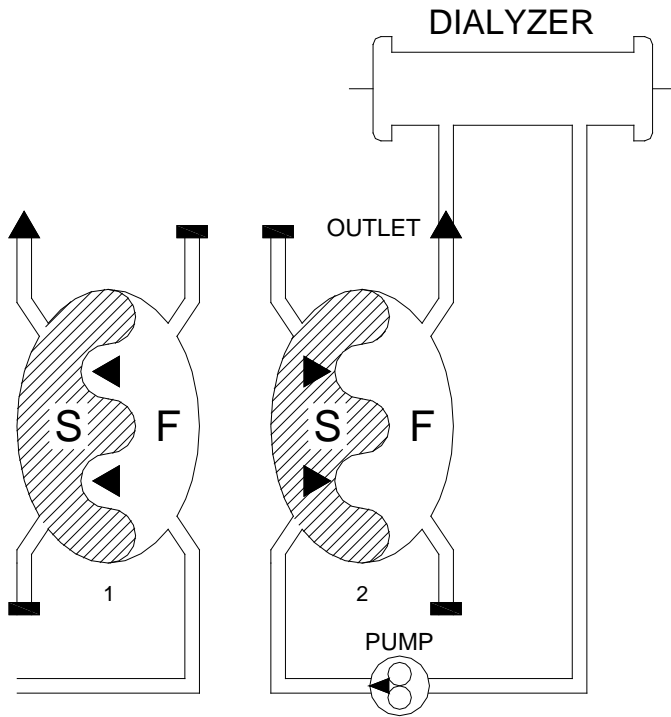

Phase 1:

In the left hand balance chamber the used dialysate is expelled by fresh dialysate. At the same time, the fresh dialysate in the right hand chamber is forced to the dialyzer by used dialysate.

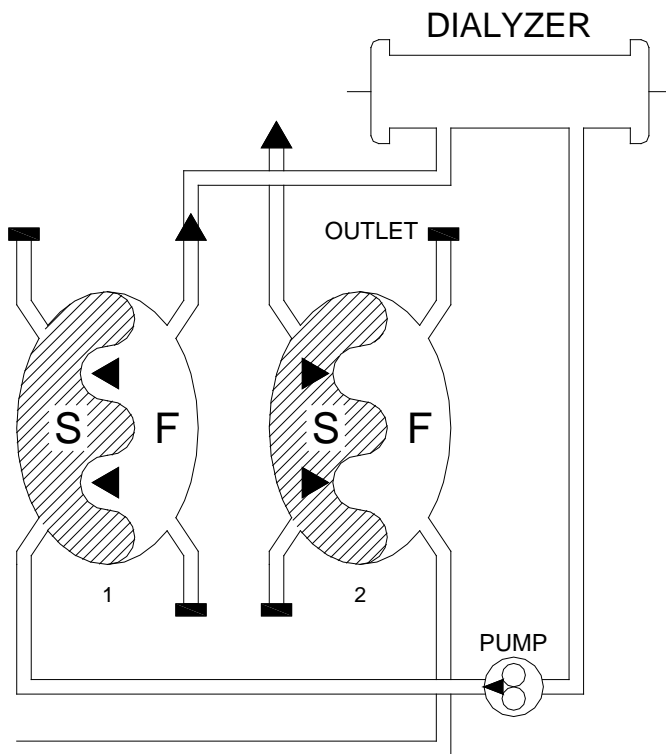

Phase 2:

The two balance chambers have interchanged their functions.

DISTRIBUTION BOARD LAYOUT

Definition of component function

- x2. Temperature control thermistor (CON-NTC)
Controls temperature in the heater chamber.
- x3. Temperature monitor thermistor (MON-NTC)
Monitors dialysate temperature before the dialyzer. Bypass is initiated when the temperature is out of limits.
- x4. Not Used
- x5. Level sensor (float) in the hydroblock/hydrochamber (FLOAT-SW)
Controls water inlet valve 41 and its signal is used to detect flow problems.
- x6. Air sensor in air separation chamber (AIR-SEN)
Detects air coming from the dialyzer and is used to trigger the filling program.
- x7. Conductivity cell (COND)
Monitors the dialysate conductivity before the dialyzer. Bypass is initiated when conductivity is out of limits.
- x8. Blood leak detector (BLOOD LEAK)
Detects blood in the return line of the dialyzer and triggers the minor blood leak warning and the blood leak alarm.
- x9. Dialysate pressure transducer (P-DIAL)
Measures the dialysate pressure. This value is used to calculate the TMP.
- x10. Chamber full switch (CFS)
The pressure spike seen by this transducer is used to switch the balance chamber. The time between pulses and the selected flow rate will set the voltage to the flow pump. It is intended to limit the height of the pressure spike to a certain value (a little higher than the loading pressure at all pump speeds).
- x11. Reed switch for acid connector (CONC-SW)
Used to detect presence of acid connector.
- x12. Reed switch for bicarbonate connector (BIC-SW)
Used to detect presence of bicarbonate connector.

Definition of component function (cont.)

- x13. Post Conductivity Cell (COND-POS)
Monitors the dialysate conductivity after the dialyzer.
- x44. Post Temperature thermister (NTC-POST)
Monitors temperature in the dialysate after the dialyzer.
- x14. Not Used
- x15. Dialysate Sampling Valve (Optional)
Valve 15
Used to collect a sample of dialysate
- x16. Acid pump with end of stroke sensor (CONC-P)
Delivers acid into the mixing chamber. It will fully discharge its volume and refill on every switching of the balance chamber.
- x17. Bicarbonate pump with end of stroke sensor (BIC-P)
Delivers bicarbonate into the mixing chamber. It will fully discharge its volume and refill (possibly twice depending on the volume needed for the acid selected) on every switching of the balance chamber.
- x18. Digital Heparin pump
- x19. Not Used
- x20. Deaeration pump (DEGAS-P)
Is calibrated in software, using a pressure gauge on the inlet of the pump.
The pressure is set to -24 inches of Hg (-610 mmHg).
- x21. Flow pump (FLOW-P)
It is controlled by software. The pump speed depends on the flow rate selected.
- x22. UF pump (UF-P)
The volume is calibrated to 1ml per stroke. The frequency of strokes is controlled by software.
- x23. Not Used
- x24. Dialyzer valve 1 (DIAL-V1)
Valve 24
- x25. Dialyzer valve 2 (DIAL-V2)
Valve 25

Definition of component function (cont.)

- x26. Bypass valve (BYPAS-V)
Valve 26
- x27. Inlet Water Valve (IN-V)
Valve 41
This valve is controlled via level sensor #5.
- x28. DIASAFE® PLUS test valve
Valve 28
Used during the DIASAFE® PLUS test process.
- x29. Recirculation valve (REC-V)
Valve 29
- x30. Drain valve (DRAIN-V)
Valve 30
- x31. Balance chamber valve 31.
- x32. Balance chamber valve 32.
- x33. Balance chamber valve 33.
- x34. Balance chamber valve 34.
- x35. Balance chamber valve 35.
- x36. Balance chamber valve 36.
- x37. Balance chamber valve 37.
- x38. Balance chamber valve 38.
- x39. Bypass valve for deaeration orifice - valve 39.
This valve is on in all cleaning cycles.
- x40. Not Used
- x41. Vent valve for air separation - valve 43.

SENSORS Ribbon cable connection from Sensor board.

ACTUATOR Ribbon cable connection from Actuator-Test board.

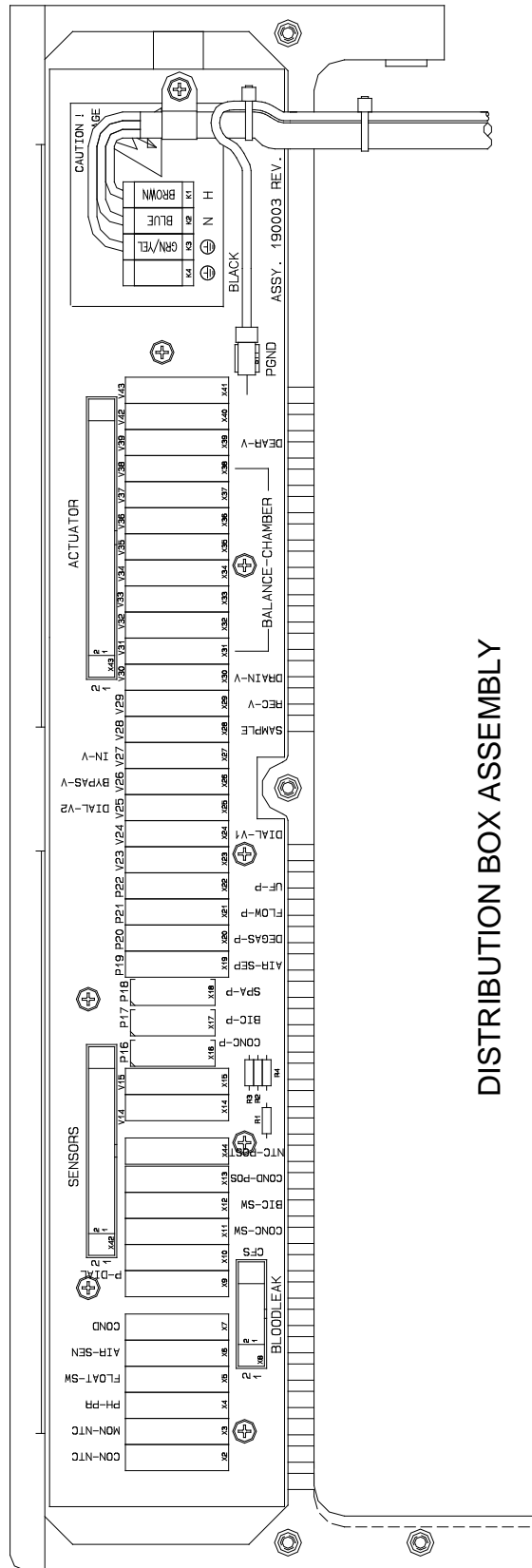

DISTRIBUTION BOX ASSEMBLY

SECTION III – ELECTRONIC CIRCUIT DESCRIPTION

BRIEF DESCRIPTION & LOCATION OF ELECTRONICS

COMPONENT	LOCATION	DESCRIPTION
Power Control board	Power Supply	Magneto-resonant power supply, 24V, heater supply, stand-by power supply and heater control circuit.
Touch Screen	Front Panel	Integral part of the front panel that handles the user inputs to the color LCD display.
Color LCD Display	Front Panel	Color LCD display with integral backlight
Front Panel Interface board	Front Panel	Interprets the touch screen and key matrix. Interfaces all LEDs on the front panel with the Functional board. Has a connection for the Power LED. Contains all LEDs except for the MUTE & RESET lights.
Mute/Reset LED board	Front Panel	Contains the LEDs for the red MUTE light and the green RESET light. Interfaces with the Front Panel Interface board.
Motherboard	Card Cage	Distribution board for card cage boards
-12 Volt Inverter board	Card Cage	-12v, Blood pressure module
Power Logic board	Card Cage	+5v, +12v, DC to DC converters.
Power Logic board w/12 Volt Inverter built-in	Card Cage	+5v, +12v, DC to DC converters and -12v for blood pressure module.
Actuator-Test board	Card Cage	Actuator: Drivers and control for valves, pumps and monitors board interface for sensor and secondary monitor (independent A/D converter) circuits. Test: Monitor for Functional board watchdog, test signal generator.
Functional board	Card Cage	Functional processor; operating logic control and control of displays
Sensor board	Card Cage	Amplifiers for pressure transducer, temperature, conductivity and other sensors, ADCs
WWD Dual Receiver board	Card Cage	If WetAlert option is enabled, this board processes RF signals from external antennas and directs information to the Functional board by serial bus.
Distribution board	Hydraulic	Interconnection of hydraulic components to the card cage
Blood Leak Detector	Hydraulic	Potted SMD board, BLD electronics

For troubleshooting purposes, refer to the 2008K@home Electronic Block Diagrams (P/N 290253) which is a set of diagrams illustrating the interconnectivity of the card cage, modules, and hydraulics.

CIRCUIT BOARD LAYOUT

CARD CAGE

LEFT TO RIGHT:
 POWER LOGIC BOARD
 ACTUATOR-TEST BOARD
 FUNCTIONAL BOARD
 SENSOR BOARD

NOT SHOWN:
 WWD DUAL RECEIVER BOARD
 (Mounted inside rear of card cage)

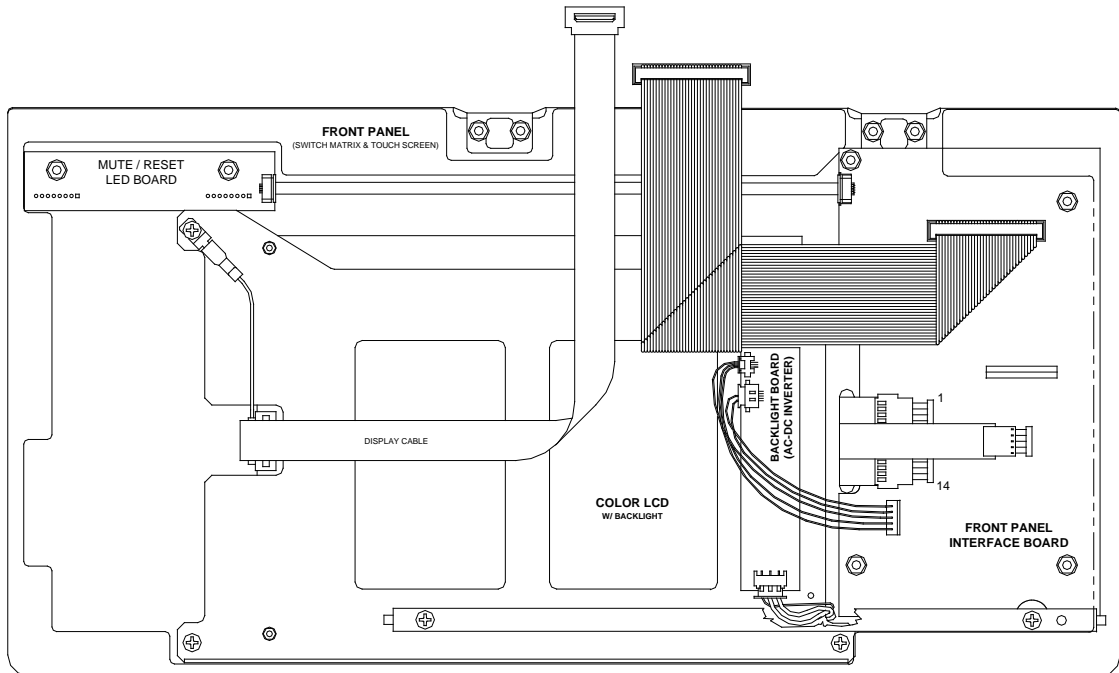
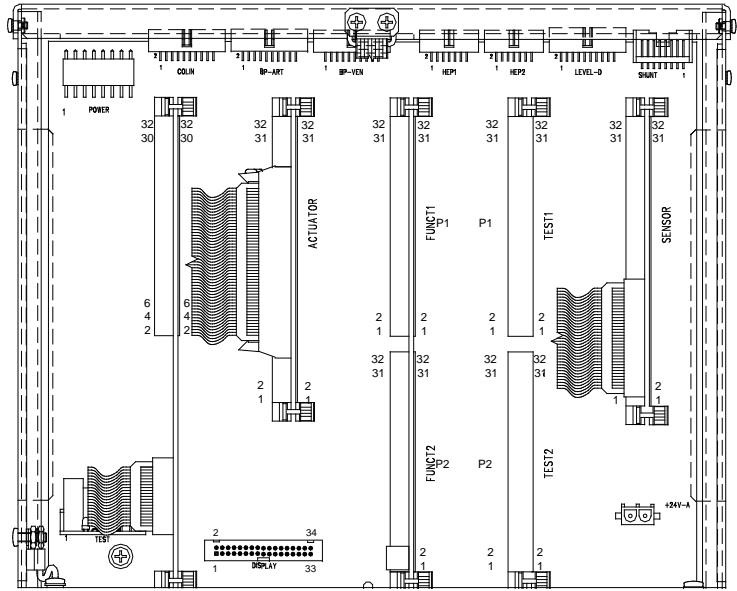

REAR PANEL OPERATING ELEMENTS

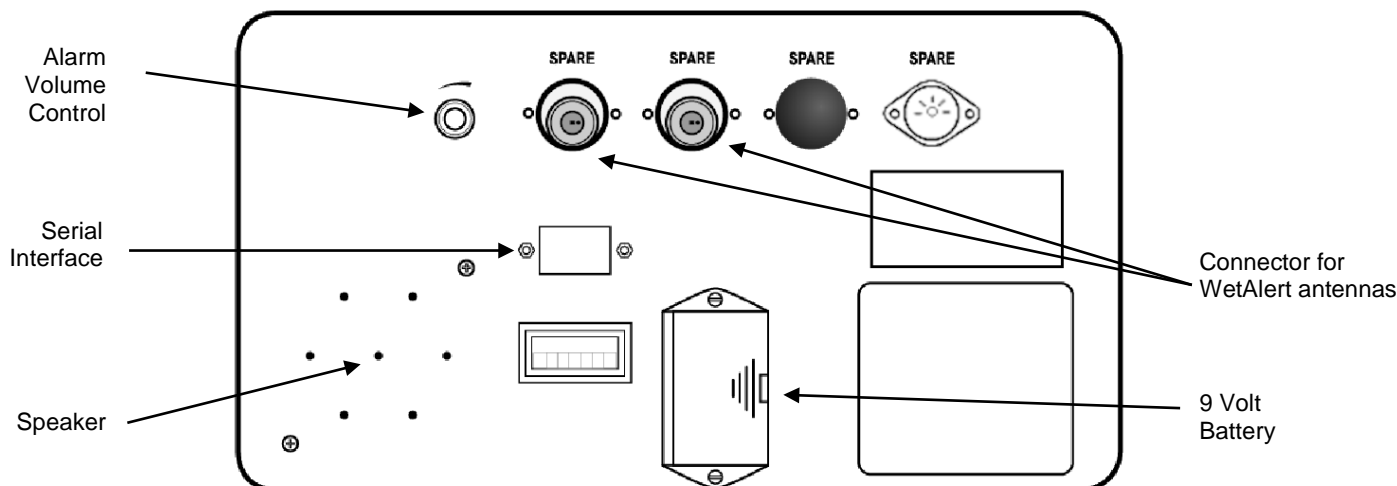

SPEAKER - The machine can make two kinds of sounds: a warning sound, and an alarm sound. The two sounds are quite distinct; the first one is used for lower priority alarms, and the second for more important alarms.

ALARM VOLUME CONTROL – Used to adjust the volume (sound pressure level) of the audible warnings and alarms. Warning sound is adjustable between 75 dBA and 89 dBA (at 1 meter). Alarm sound is adjustable between 67 dBA and 81 dBA (at 1 meter).

SERIAL INTERFACE - Electrically isolated RS 232 serial interface connector; used for transferring machine data to a medical information system.

POWER FAILURE ALARM - 9V heavy duty alkaline battery for main power failure

HYDRAULIC CONNECTION PANEL

TO DIALYZER - tube to dialyzer

FROM DIALYZER - tube from dialyzer

WATER INLET - tube for water inlet

TO DRAIN - outlet tube to drain

GROUND - fixing screw for potential equalization

POWER SUPPLY PANEL

HEATER BREAKER - separate line voltage breaker for heater element

MAIN BREAKER - main line voltage switch



Note: To isolate machine from mains supply, toggle this switch to the O position.

POWER CABLE - cable connection to wall GFCI



Note: The power supply cord is replaceable by service personnel only. Refer to the 2008 Power Cord Replacement Instructions included in 2008 Power Supply Cord Replacement Kit (P/N 190714) for correct connection and anchoring of the power cord.

ELECTRONIC BOARD DESCRIPTIONS

FRONT PANEL AND DISPLAY

1. OVERVIEW

The front panel assembly provides control input and visual feedback of the current operational status of the 2008K@home. The five major components of the front panel assembly are the Front Panel with Touch Screen, the Front Panel Interface board, the Mute/Reset LED board, the LCD display, and the Backlight Inverter board*.

The Front Panel consists of a metal base plate with a plastic overlay. The Front Panel Interface board, the LCD display, and the Mute/Reset LED board are attached to the Front Panel using PEM studs. The metal base plate has cutouts that correspond to the locations where the LEDs on the Front Panel Interface board and the Mute/Reset LED board will show through, and for where the LCD display is mounted. The plastic overlay is silk-screened with text and shaded squares to show the location of the membrane switches that are embedded within the overlay. Also incorporated in the plastic overlay are colored lenses over the cutouts for the LEDs. The cutout for the LCD display incorporates the Touch Screen used to interface directly with the LCD display.

The Front Panel Interface board provides the interface and control for the LEDs, the keyboard matrix, the Touch Screen and the Backlight Inverter board*. Several different types and colors of LED modules are used to display the status and operating mode of the 2008K@home. The Functional board provides the data that drives the LEDs and the LCD display. The backlight for LCD display is driven by the Backlight Inverter board*.

The LCD display is a 640 x 480 pixel graphic display module through which extensive textual and graphical information can be displayed pertaining to the current operational status, diagnostics functions, or calibrations. All of these are controlled by the Functional board under software control.

* Newer LCD Displays have LED backlighting and do not require a Backlight Inverter board.

2. LEDs

The front panel has 5 LEDs, 4 of which are controlled by the Functional board. These are used primarily to indicate alarms and machine states. A flashing LED either may indicate the first blood alarm, when multiple blood alarms occur; or a key that user can press for a special response. During the light show, the LEDs are tested, one by one. At other times, they have the following meanings:

1. **Power** - Lit indicates the machine is on.
2. **Mute** - Lit if muting is active.
3. **Reset** – Normally not lit. Lit if alarm is active. Flashing if the message displayed asks the user if they want new arterial, venous, or TMP limits (blood alarm).
4. **Stat/Deflate** - Lit when Blood Pressure Cuff is pressurized.
5. **UF On/Off** - Flashes if there is a blood alarm or treatment time is paused. Lit if UF is actually on or the user turns it on. Off if the user turns the UF off.

3. MEMBRANE SWITCHES

The membrane switches embedded in the Front Panel overlay are spring-loaded, momentary action, contact type switches. The membrane switch signals are connected through a flexible cable that plugs into Front Panel Interface board connector P2. The Front Panel Interface board simply buses these signals from connector JP3 to JP1. From JP1, these signals are routed to the Motherboard through a short ribbon cable assembly. The membrane switch signals are then routed to the appropriate boards through the Motherboard.

The Power ON/OFF membrane switch, when pressed, grounds the PWR-ON signal to the Power Logic board. This causes the Power ON/OFF circuit on the Power Logic board to change state. The current state of this circuit will determine whether pressing the Power ON/OFF membrane switch turns the main power ON or OFF.

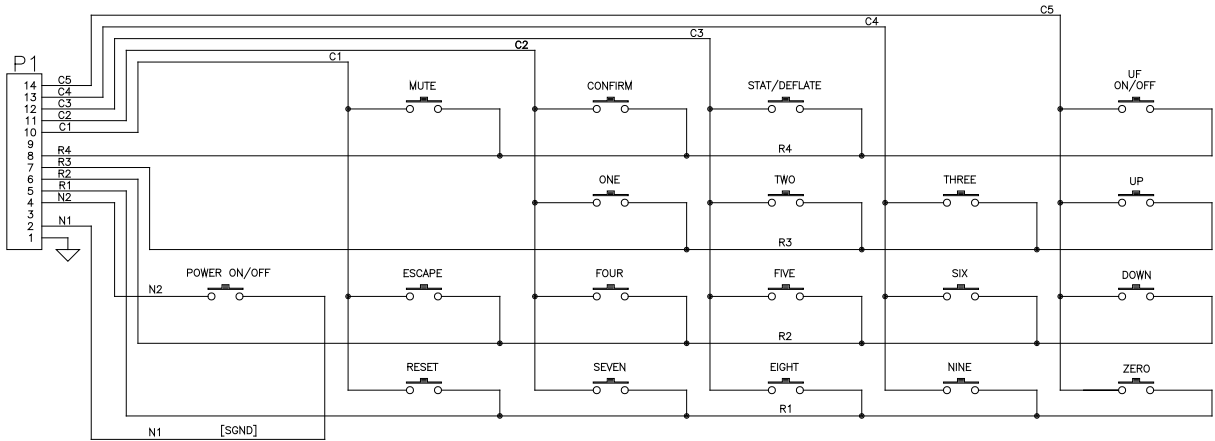

The remaining membrane switches are scanned by the Functional board to determine the action that will be taken in response to the membrane switch pressed.

There are 19 keys on the front panel. 18 of them cause a keyboard interrupt to occur; debouncing is handled in the interrupt, and the key may be passed on to the section of the program that will process it. The Power on/off key cannot be read by the Functional board. The Power on/off key is handled by the Power Logic board.

The functions of the keys are as follows:

- a. Mute
Mute alarm and warning sounds for 2 minutes, if not already muting and an alarm or warning exists. Outside of dialysis, allow muting of warning sounds. Note that muting is turned off whenever a new alarm occurs. Note that fatal alarms (which shut down the machine) cannot be muted.
- b. RESET
Pressing the RESET key clears clearable alarms. Pressing and holding the key for two seconds will spread the alarm window by 300 mmHg for arterial and venous pressures and fully open the transmembrane (TMP) pressure window for 30 seconds. During this time, the light above the RESET key will not be on. During a blood leak alarm, pressing and holding the key for three seconds will override the alarm and keep the blood pump running for three minutes. The light above the RESET key will be on during an override.



Warning! During an override, the machine's blood leak detector is inactive. You must monitor the treatment.



Note: The Reset key light flashes when a resettable alarm occurs.

- c. Escape
The Escape key is used to cancel a change to a parameter.
- d. Number Keys (0-9)
These keys are used to enter parameters.
- e. Up
This key is used to edit a variable, to increase its value and scrolls up when selecting from a menu. Also, can cycle through the debug screens.

- f. Down
This key is used to edit a variable, to decrease its value and scrolls down when selecting from a menu. Also, can cycle through the debug screens.
- g. CONFIRM
The CONFIRM key is used to accept changed parameters on a screen and to accept an action as defined on various screens
- h. Stat/Deflate
Press the Stat/Deflate to Start or Stop a Blood Pressure reading.
- i. UF On/Off
If the user has turned UF on (though it may be interrupted by an alarm) this key turns it off. If UF is off, and the machine is in dialysis, and there are no blood alarms and no UF Pump Alarm, and there is no Maximum UF Rate Warning, and the UF rate selected is at least 10 ml/hour, then pressing this key will turn UF on.
- j. Debug Screen Key
This “key” (generated by pressing up and down keys at the same time causes the debugging screens to be brought up.

ACTUATOR-TEST BOARD

The Actuator-Test board combines the functionality of an Actuator and Test boards. For the purpose of clarity, they can be described separately.

ACTUATOR BOARD FUNCTIONALITY

1. OVERVIEW

The main functions of the Actuator board are to control the hydraulic system of the dialysis machine, communicate with the Functional board and also monitors the system to determine if the machine is working properly. Also provides redundancy to Sensor board for hard limits (alarm) checking. If not, it will send alarm(s) to the Functional board through the communication and take corresponding action to the hydraulic system to make sure that the machine is absolutely safe.

2. PROGRAM FLOW

When the machine is turned on, it first goes through an initialization sequence. Then it goes into an endless loop. All program activities happen in this loop as background tasks while waiting for the interrupt. Within this loop it first reads in all necessary hardware data such as: flow switch on/off, dial lines in/out, shunt door open/close, acid and bicarbonate wands in/out, bicarbonate and acid pump end of stroke signal, state of the dip switches, blood sensed signal, etc. There is a 10 ms timer interrupt that controls the machine steps. If the 10 ms is not up, the program will update every valve, process the communication data coming from the Functional board and update the data, which will be sent to the Functional board.

When the 10 ms timer interrupt occurs, it first resets the interrupt flag for the next interrupt, updates the balance chamber switch counter and the run time counter which remembers how long the machine runs, reads some ADC channels, and then if the machine is just started and the deaeration pump steps have been received from the Functional board, does the preparation for the hydraulic system (only once when the machine starts up).

After the preparation is done, the machine is in the no program state, which means the machine sets up the main menu waiting for a command from the Functional board. Depending upon the command, the machine executes the dialysis program or one of the rinse/disinfect program or calibration program. Also the Actuator board does redundant monitoring within this 10ms. The redundant monitoring checks bicarbonate and acid pumps, checks the flow, the UF pump, the temperature and conductivity limits, the arterial, venous, and TMP pressure limits, monitors water alarms, monitors blood alarms, and shuts off the machine if a water alarm or blood alarm or Actuator board EPROM CRC error occurs for a certain period of time. Also, the heater will be controlled based on different alarm conditions.



Note: All references to “Actuator board” actually refer to the Actuator-Test board.

3. ALARMS

There are many alarms generated by the Actuator board. These alarms are displayed by the Functional board.

4. ADC CHANNELS

There are 8 A to D channels:

- (1). Channel 0: Read in Chamber Full Switch.
- (2). Channel 1: Read in dialysate pressure.
- (3). Channel 2: Read in arterial pressure.
- (4). Channel 3: Read in venous pressure.
- (5). Channel 4: Read in temperature.
- (6). Channel 5: Read in blood leak voltage.
- (7). Channel 6: Read in 1.2V reference.
- (8). Channel 7: Read in 24V.

TEST BOARD FUNCTIONALITY

There are three test areas in the 2008K@home, the Tx Setup Test, the Blood Line Test, and in the Help Screen Test (Both Tests, Alarm Test, Pressure Test and DIASAFE® PLUS Filter Test).

A. Tx Setup Test

During the process of setting up the machine, right after the concentrate being used is confirmed the Tx Setup Test must be performed. This test includes the following steps:

- Negative Pressure
- Positive Pressure
- Zero Art/Venous Pressure
- Blood Leak
- Battery
- Optical Detector
- Temperature
- Conductivity

Once the Tx Setup Test is started there will be banners displayed indicating what process is being performed.

The Tx Setup Test will not start if the TX Clock is running, if the dialysate lines are not in the shunt box, or if blood is sensed. All tests are performed at a 500ml/min flow rate.

The following table shows the sequence in which each banner is displayed during the Tx Setup Test and what process is being performed:

Tx Setup Test Banner Sequence	Process Being Performed
Test: (Remove Air)	Air is removed from the system by creating an air fill program if needed
Test: (Get Neg TMP)	Positive pressure is achieved, and then a dialysate pressure of at least -270 is reached
Test: Neg Flow On	There is a 30 second delay for the pressure to stabilize (the test fails if during this time the pressure is out of the range of -250 to -450), and then a 30 second test, during which the dialysate pressure must not vary more than a 21mmHg
Test: (Get Pos TMP)	A dialysate pressure of at least +350 is achieved (to check the upper most end of the scale)
Test: POS Flow Off	There is a 20 second delay for the pressure to stabilize (the test fails if during this time the pressure is out of the range +180 to +350), and then a 30 second test, during which the TMP must not vary more than 30 mmHg

Tx Setup Test Banner Sequence (cont.)	Process Being Performed
Test: (Get Neg TMP)	A TMP of at least -100 is reached
<p>The Arterial and Venous pressures are tested to verify they are zero.</p> <p>(Note: Since this process happens quickly, the message banner may not be seen. Also, the Arterial Pressure is only tested if the 0 Art Limit option is selected in Service Mode.)</p>	
Test: (Get Neg TMP)	Positive pressure is achieved, and then a TMP of at least -100 is reached
Test: Blood Leak	The Test board detunes the blood leak detector. The blood leak detector reacts by reducing the output signal below the normal alarm threshold. Functional board reacts by detecting the alarm.
Test: 9 Volt Battery	The Test board sets TEST-BAT signal to 5V. This causes a load to be connected across the battery. The battery is now checked for a voltage greater than 7V. If the alkaline battery voltage is above 7V the test passes. The TEST-BAT signal is removed.
Test: Optical Detector	The Test board detunes the optical detector and a blood sensed indication must be received for the test to pass.
Test: Temp High Hard	The Test board detunes the actual temperature value so that it is above the high hard limit to test that the machine goes into bypass and the heater relay turns off.
Test: Temp Low Hard	The Test board detunes the actual temperature value so that it is below the low hard limit to test that the machine goes into bypass.
Test: Temp High Soft	The Test board detunes the actual temperature value so that it is above the high soft limit to test that the machine goes into bypass.
Test: Temp Low Soft	The Test board detunes the actual temperature value so that it is above the low soft limit to test that the machine goes into bypass.
Test: Cond High Soft	The Test board detunes the actual conductivity value so that it is above the high soft limit to test that the machine goes into bypass.
Test: Cond Low Soft	The Test board detunes the actual conductivity value so that it is above the low soft limit to test that the machine goes into bypass.

B. Blood Line Test

After the tubing has been primed, a Blood Line Test must be performed.

Once the Blood Line Test is started there will be banners displayed indicating what process is being performed.

The Blood Line Test will not start if the TX Clock is running, if the dialysate lines are in the shunt box, or if blood is sensed. All tests are performed at a 500ml/min flow rate.

The following table shows the sequence in which each banner is displayed during the Blood Line Test and what process is being performed:

Blood Line Test Banner Sequence	Process Being Performed
Test: (Get Neg TMP)	Air is removed from the system by creating an air fill program if needed then a negative pressure (-100) is achieved
Test: Air Detector	The Test board sets LDSA signal to 5V. This causes the level detector to reduce the ultrasonic signal across the level detector by 1/3. The level detector reacts by closing the clamp and sending an alarm condition to the Functional board. The Functional board shuts off the blood systems and turns the level detector alarm led on. The Test board monitors the clamp close and the blood pump off.
Test: Art High Hard	The Test board sets the detuning DAC to 0V and then turns on the CMOS switch. The zero adjustment for the arterial pressure transducer is pulled low. Using the equation of the circuit $V_{out} = f(\text{gain}) * V_{\text{gain}} - f(\text{offset}) * V_{\text{offset}} + 5V$, a low to the offset adjustment causes a V_{out} considerably above 5V. The Functional board along with the ADC on the Sensor board measures this detuned arterial pressure of over 350mmHg. The Functional board reacts to the upper hard limit alarm by turning off the blood pump. The Test board senses the blood pump off. The Test board turns the CMOS switch off.
Test: Art Low Hard	The Test board sets the detuning DAC to 10V and then turns on the CMOS switch. The 0 adjustment for the arterial pressure transducer is pulled high. Using the equation of the circuit $V_{out} = f(\text{gain}) * V_{\text{gain}} - f(\text{offset}) * V_{\text{offset}} + 5V$, a high to the offset adjustment causes a V_{out} considerably below 5V. The Functional board along with the ADC on the Sensor board measures this detuned arterial pressure of under -300 mmHg. The Functional board reacts to the lower hard limit alarm by turning off the blood pump. The Test board senses the blood pump off. The Test board turns the CMOS switch off.

Blood Line Test Banner Sequence (cont.)	Process Being Performed
Test: Art High Soft	The Test board sets the detuning DAC to a value between 1V and 4V. The TP then turns on the CMOS switch. The 0 adjustment for the arterial pressure transducer is pulled low. Using the equation of the circuit $V_{out} = f(\text{gain}) * V_{\text{gain}} - f(\text{offset}) * V_{\text{offset}} + 5V$, a low to the offset adjustment causes a V_{out} above 5V. The Functional board along with the ADC on the Sensor board measures this detuned arterial pressure of around 200 mmHg. After 5 seconds, the Functional board reacts to the upper auto-limit alarm by turning off the blood pump. The Test board senses the blood pump off. Alarms are cleared; the auto-limits are set around this new actual arterial pressure.
Test: Art Low Soft	The Test board turns off the CMOS switch. Arterial pressure returns to 0 mmHg. After 5 seconds, the Functional board reacts to the lower auto-limit alarm by turning off the blood pump. The Test board senses the blood pump off. The Test board turns the CMOS switch off.
Test: Ven High Hard	Same as the Art High Hard test but with the venous pressure transducer on the level detector.
Test: Ven Low Hard	Same as the Art Low Hard test but with the venous pressure transducer on the level detector.
Test: Ven High Soft	Same as the Art High Soft test but with the venous pressure transducer on the level detector.
Test: Ven Low Soft	Same as the Art Low Soft test but with the venous pressure transducer on the level detector.
Test: TMP High Hard	Same as the Art High Hard test but with the dialysate pressure transducer.
Test: TMP Low Hard	Same as the Art Low Hard test but with the dialysate pressure transducer.
Test: TMP High Soft	Same as the Art High Soft test but with the dialysate pressure transducer.
Test: TMP Low Soft	Same as the Art Low Soft test but with the dialysate pressure transducer.

C. Help Screen Test

The Help Screen Test allows the user to perform tests to troubleshoot the machine. These tests include an Alarm Test, a Pressure Test, Both Alarm and Pressure Tests, and a DIASAFE® PLUS Filter Test.

Both Tests Button:

The Both Tests button performs the Alarm Test and the Pressure Test. These tests include the following tests:

- Air Detector
- Blood Leak
- Arterial Pressure
- Venous Pressure
- TMP Pressure
- Battery
- Optical Detector
- Temperature
- Conductivity
- Negative Pressure
- Positive Pressure

Once Both Tests is started there will be banners displayed indicating what process is being performed.

Both Tests will only start if the machine is alarm free, the TX Clock is not running, the dialysate lines are in the shunt box, and blood is not sensed. All tests are performed at a 500ml/min flow rate.

The following table shows the sequence in which each banner is displayed during the performance of Both Tests and what process is being performed:

Both Tests Banner Sequence	Process Being Performed
Test: (Get Neg TMP)	Air is removed from the system by creating an air fill program if needed then a negative pressure (-100) is achieved
Test: Air Detector	The Test board sets LDSA signal to 5V. This causes the level detector to reduce the ultrasonic signal across the level detector by 1/3. The level detector reacts by closing the clamp and sending an alarm condition to the Functional board. The Functional board shuts off the blood systems and turns the level detector alarm led on. The Test board monitors the clamp close and the blood pump off.
Test: Blood Leak	The Test board detunes the blood leak detector. The blood leak detector reacts by reducing the output signal below the normal alarm threshold. Functional board reacts by closing the clamp and shutting off the blood pump. Functional board monitors the blood pump stopped.

Both Tests Banner Sequence (cont.)	Process Being Performed
Test: Art High Hard	The Test board sets the detuning DAC to 0V and then turns on the CMOS switch. The zero adjustment for the arterial pressure transducer is pulled low. Using the equation of the circuit $V_{out} = f(\text{gain}) * V_{\text{gain}} - f(\text{offset}) * V_{\text{offset}} + 5V$, a low to the offset adjustment causes a V_{out} considerably above 5V. The Functional board along with the ADC on the Sensor board measures this detuned arterial pressure of over 350 mmHg. The Functional board reacts to the upper hard limit alarm by turning off the blood pump. The Test board senses the blood pump off. The Test board turns the CMOS switch off.
Test: Art Low Hard	The Test board sets the detuning DAC to 10V and then turns on the CMOS switch. The 0 adjustment for the arterial pressure transducer is pulled high. Using the equation of the circuit $V_{out} = f(\text{gain}) * V_{\text{gain}} - f(\text{offset}) * V_{\text{offset}} + 5V$, a high to the offset adjustment causes a V_{out} considerably below 5V. The Functional board along with the ADC on the Sensor board measures this detuned arterial pressure of under -300 mmHg. The Functional board reacts to the lower hard limit alarm by turning off the blood pump. The Test board senses the blood pump off. The Test board turns the CMOS switch off.
Test: Art High Soft	The Test board sets the detuning DAC to a value between 1V and 4V. The TP then turns on the CMOS switch. The 0 adjustment for the arterial pressure transducer is pulled low. Using the equation of the circuit $V_{out} = f(\text{gain}) * V_{\text{gain}} - f(\text{offset}) * V_{\text{offset}} + 5V$, a low to the offset adjustment causes a V_{out} above 5V. The Functional board along with the ADC on the Sensor board measures this detuned arterial pressure of around 200 mmHg. After 5 seconds, the Functional board reacts to the upper auto-limit alarm by turning off the blood pump. The Test board senses the blood pump off. Alarms are cleared; the auto-limits are set around this new actual arterial pressure.
Test: Art Low Soft	The Test board turns off the CMOS switch. Arterial pressure returns to 0 mmHg. After 5 seconds, the Functional board reacts to the lower auto-limit alarm by turning off the blood pump. The Test board senses the blood pump off. The Test board turns the CMOS switch off.
Test: Ven High Hard	Same as the Art High Hard test but with the venous pressure transducer on the level detector.
Test: Ven Low Hard	Same as the Art Low Hard test but with the venous pressure transducer on the level detector.
Test: Ven High Soft	Same as the Art High Soft test but with the venous pressure transducer on the level detector.
Test: Ven Low Soft	Same as the Art Low Soft test but with the venous pressure transducer on the level detector.

Both Tests Banner Sequence (cont.)	Process Being Performed
Test: TMP High Hard	Same as the Art High Hard test but with the dialysate pressure transducer.
Test: TMP Low Hard	Same as the Art Low Hard test but with the dialysate pressure transducer.
Test: TMP High Soft	Same as the Art High Soft test but with the dialysate pressure transducer.
Test: TMP Low Soft	Same as the Art Low Soft test but with the dialysate pressure transducer.
Test: 9 Volt Battery	The Test board sets TEST-BAT signal to 5V. This causes a load to be connected across the battery. The battery is now checked for a voltage greater than 7V. If the alkaline battery voltage is above 7V the test passes. The TEST-BAT signal is removed.
Test: Optical Detector	The Test board detunes the optical detector and a venous pressure alarm must occur for the test to pass.
Test: Temp High Hard	The Test board detunes the actual temperature value so that it is above the high hard limit to test that the machine goes into bypass and the heater relay turns off.
Test: Temp Low Hard	The Test board detunes the actual temperature value so that it is below the low hard limit to test that the machine goes into bypass.
Test: Temp High Soft	The Test board detunes the actual temperature value so that it is above the high soft limit to test that the machine goes into bypass.
Test: Temp Low Soft	The Test board detunes the actual temperature value so that it is above the low soft limit to test that the machine goes into bypass.
Test: Cond High Soft	The Test board detunes the actual conductivity value so that it is above the high soft limit to test that the machine goes into bypass.
Test: Cond Low Soft	The Test board detunes the actual conductivity value so that it is above the low soft limit to test that the machine goes into bypass.
Test: (Remove Air)	Air is removed from the system by creating an air fill program if needed
Test: (Get Neg TMP)	Positive pressure is achieved, and then a dialysate pressure of at least -270 is reached
Test: Neg Flow On	There is a 30 second delay for the pressure to stabilize (the test fails if during this time the pressure is out of the range of -250 to -450), and then a 30 second test, during which the dialysate pressure must not vary more than a 21 mmHg

Both Tests Banner Sequence (cont.)	Process Being Performed
Test: (Get Pos TMP)	A dialysate pressure of at least +350 is achieved (to check the upper most end of the scale)
Test: POS Flow Off	There is a 20 second delay for the pressure to stabilize (the test fails if during this time the pressure is out of the range +180 to +350), and then a 30 second test, during which the TMP must not vary more than 30 mmHg
Test: (Get Neg TMP)	Positive pressure is achieved, and then a TMP of at least -100 is reached

Pressure Test Button:

The Pressure Test button performs the following tests:

- Negative Pressure
- Positive Pressure

Once the Pressure Test is started there will be banners displayed indicating what process is being performed.

The Pressure Test will only start if the machine is alarm free, the TX Clock is not running, the dialysate lines are in the shunt box, and blood is not sensed. All tests are performed at a 500ml/min flow rate.

The following table shows the sequence in which each banner is displayed during the Pressure Test and what process is being performed:

Pressure Test Banner Sequence	Process Being Performed
Test: (Remove Air)	Air is removed from the system by creating an air fill program if needed
Test: (Get Neg TMP)	Positive pressure is achieved, and then a dialysate pressure of at least -270 is reached
Test: Neg Flow On	There is a 30 second delay for the pressure to stabilize (the test fails if during this time the pressure is out of the range of -250 to -450), and then a 30 second test, during which the dialysate pressure must not vary more than a 21mmHg
Test: (Get Pos TMP)	A dialysate pressure of at least +350 is achieved (to check the upper most end of the scale)
Test: POS Flow Off	There is a 20 second delay for the pressure to stabilize (the test fails if during this time the pressure is out of the range +180 to +350), and then a 30 second test, during which the TMP must not vary more than 30mmHg. 30 seconds for both on Diasafe equipped machines.
Test: (Get Neg TMP)	Positive pressure is achieved, and then a TMP of at least -100 is reached

Alarm Test Button:

The Alarm Test button performs the following tests:

- Air Detector
- Blood Leak
- Arterial Pressure
- Venous Pressure
- TMP Pressure
- Battery
- Optical Detector
- Temperature
- Conductivity

Once the Alarm Test is started there will be banners displayed indicating what process is being performed.

The Alarm Test will only start if the machine is alarm free, the TX Clock is not running, the dialysate lines are in the shunt box, and blood is not sensed. All tests are performed at a 500ml/min flow rate.

The following table shows the sequence in which each banner is displayed during the Alarm Test and what process is being performed:

Alarm Test Banner Sequence	Process Being Performed
Test: (Get Neg TMP)	Air is removed from the system by creating an air fill program if needed then a negative pressure (-100) is achieved
Test: Air Detector	The Test board sets LDSA signal to 5V. This causes the level detector to reduce the ultrasonic signal across the level detector by 1/3. The level detector reacts by closing the clamp and sending an alarm condition to the Functional board. The Functional board shuts off the blood systems and turns the level detector alarm led on. The Test board monitors the clamp close and the blood pump off.
Test: Blood Leak	The Test board detunes the blood leak detector. The blood leak detector reacts by reducing the output signal below the normal alarm threshold. Functional board reacts by closing the clamp and shutting off the blood pump. Functional board monitors the blood pump stopped.

Alarm Test Banner Sequence (cont.)	Process Being Performed
Test: Art High Hard	The Test board sets the detuning DAC to 0V and then turns on the CMOS switch. The zero adjustment for the arterial pressure transducer is pulled low. Using the equation of the circuit $V_{out} = f(\text{gain}) * V_{\text{gain}} - f(\text{offset}) * V_{\text{offset}} + 5V$, a low to the offset adjustment causes a V_{out} considerably above 5V. The Functional board along with the ADC on the Sensor board measures this detuned arterial pressure of over 350mmHg. The Functional board reacts to the upper hard limit alarm by turning off the blood pump. The Test board senses the blood pump off. The Test board turns the CMOS switch off.
Test: Art Low Hard	The Test board sets the detuning DAC to 10V and then turns on the CMOS switch. The 0 adjustment for the arterial pressure transducer is pulled high. Using the equation of the circuit $V_{out} = f(\text{gain}) * V_{\text{gain}} - f(\text{offset}) * V_{\text{offset}} + 5V$, a high to the offset adjustment causes a V_{out} considerably below 5V. The Functional board along with the ADC on the Sensor board measures this detuned arterial pressure of under -300mmHg. The Functional board reacts to the lower hard limit alarm by turning off the blood pump. The Test board senses the blood pump off. The Test board turns the CMOS switch off.
Test: Art High Soft	The Test board sets the detuning DAC to a value between 1V and 4V. The TP then turns on the CMOS switch. The 0 adjustment for the arterial pressure transducer is pulled low. Using the equation of the circuit $V_{out} = f(\text{gain}) * V_{\text{gain}} - f(\text{offset}) * V_{\text{offset}} + 5V$, a low to the offset adjustment causes a V_{out} above 5V. The Functional board along with the ADC on the Sensor board measures this detuned arterial pressure of around 200 mmHg. After 5 seconds, the Functional board reacts to the upper auto-limit alarm by turning off the blood pump. The Test board senses the blood pump off. Alarms are cleared, the auto-limits are set around this new actual arterial pressure.
Test: Art Low Soft	The Test board turns off the CMOS switch. Arterial pressure returns to 0 mmHg. After 5 seconds, the Functional board reacts to the lower auto-limit alarm by turning off the blood pump. The Test board senses the blood pump off. The Test board turns the CMOS switch off.
Test: Ven High Hard	Same as the Art High Hard test but with the venous pressure transducer on the level detector.
Test: Ven Low Hard	Same as the Art Low Hard test but with the venous pressure transducer on the level detector.
Test: Ven High Soft	Same as the Art High Soft test but with the venous pressure transducer on the level detector.
Test: Ven Low Soft	Same as the Art Low Soft test but with the venous pressure transducer on the level detector.

Alarm Test Banner Sequence (cont.)	Process Being Performed
Test: TMP High Hard	Same as the Art High Hard test but with the dialysate pressure transducer.
Test: TMP Low Hard	Same as the Art Low Hard test but with the dialysate pressure transducer.
Test: TMP High Soft	Same as the Art High Soft test but with the dialysate pressure transducer.
Test: TMP Low Soft	Same as the Art Low Soft test but with the dialysate pressure transducer.
Test: 9 Volt Battery	The Test board sets TEST-BAT signal to 5V. This causes a load to be connected across the battery. The battery is now checked for a voltage greater than 7V. If the alkaline battery voltage is above 7V the test passes. The TEST-BAT signal is removed.
Test: Optical Detector	The Test board detunes the optical detector and a blood sensed indication must be received for the test to pass.
Test: Temp High Hard	The Test board detunes the actual temperature value so that it is above the high hard limit to test that the machine goes into bypass and the heater relay turns off.
Test: Temp Low Hard	The Test board detunes the actual temperature value so that it is below the low hard limit to test that the machine goes into bypass.
Test: Temp High Soft	The Test board detunes the actual temperature value so that it is above the high soft limit to test that the machine goes into bypass.
Test: Temp Low Soft	The Test board detunes the actual temperature value so that it is above the low soft limit to test that the machine goes into bypass.
Test: Cond High Soft	The Test board detunes the actual conductivity value so that it is above the high soft limit to test that the machine goes into bypass.
Test: Cond Low Soft	The Test board detunes the actual conductivity value so that it is above the low soft limit to test that the machine goes into bypass.

Diasafe Test Button:



Note: The Diasafe Test button is only visible on the Help screen if the Diasafe and the Diasafe Auto-Test options are set to Yes in the Option in Hardware Options of Service Mode.

The Diasafe Test will not start if the dialysate lines are not in the shunt box or if blood is sensed.

When the Diasafe Test starts the dialysate flow is turned off and the UF Removed is zeroed. Valves V24 and V25 are turned on and V26 is turned off. The Diasafe Test valve V28 is turned on. The UF Rate is set to 4000ml/min and allowed to stroke for 100 strokes. The dialysate pressure is noted and the UF Rate is changed to 2000ml/min. If the dialysate pressure rises by 60mmHg from the noted reading and reaches above 300 mmHg, the Diasafe Test passes and displays the “Diasafe Test Passed” banner.

If the dialysate pressure doesn't rise by 60 mmHg and reaches 300 mmHg by the time the UF pump reaches 160 strokes, then the Diasafe Test fails and displays the “Diasafe Test Failed” banner.

FUNCTIONAL BOARD

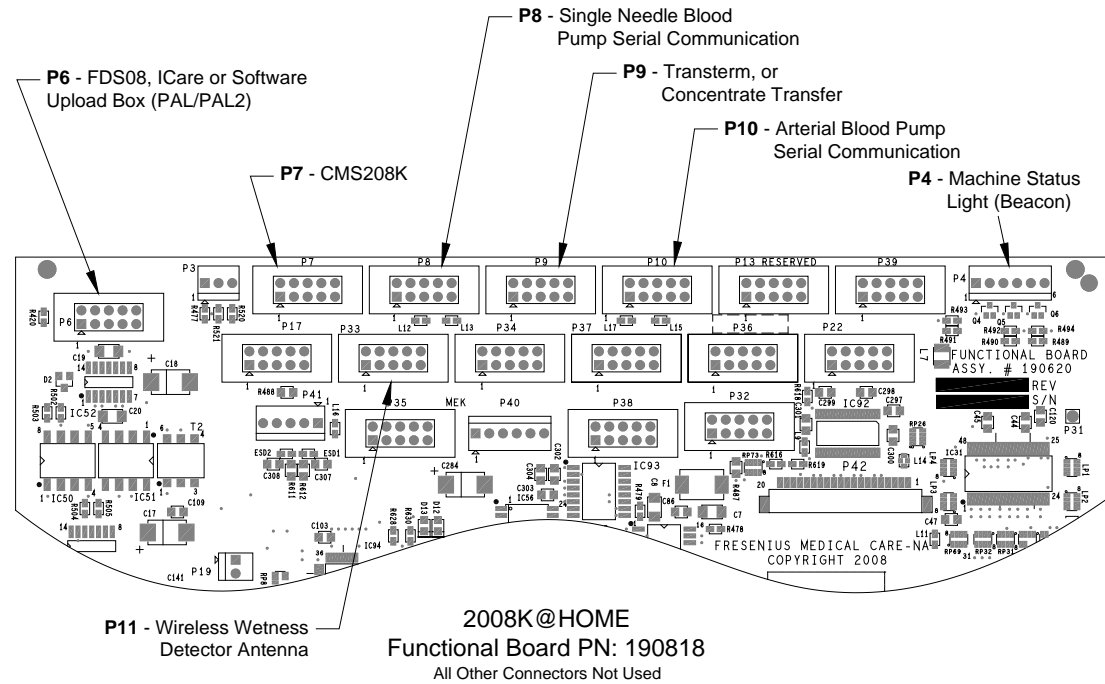
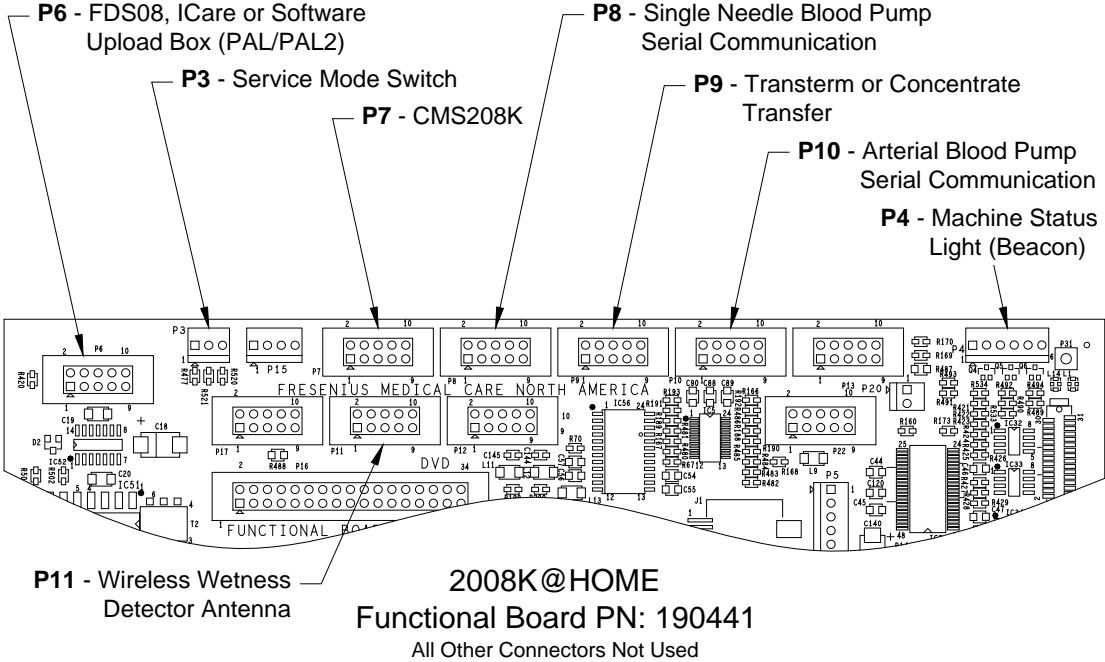

SENSOR BOARD

A-to-D CHANNELS

There are 16 a-to-d channels, numbered 0 to 15:

Channel	Volts	Name	Use
0	12.0	BLOOD-LEAK	Blood leak detector
1	12.0	BLOOD-DIMNESS	Blood dimness
2	12.0	ART-PRESSURE	Arterial pressure
3	12.0	VEN-PRESSURE	Venous pressure
4	12.0	DIAL-PRESSURE	Dialysate pressure
5	12.0	TEMPERATURE	Temperature
6	11.5	ART-DELIVERY	Arterial blood pump delivery rate
7	11.5	VEN-DELIVERY	Venous blood pump delivery rate
8	6.0	5-VOLTS	5 volts
9	30.0	24-VOLTS	24 volts
10	12.0	ART-KNOB	Arterial blood pump user setting
11	12.0	VEN-KNOB	Venous blood pump user setting
12	30.0	UNUSED	Unused
13	12.0	INLET	Inlet pressure (CFS)
14	0.0	UNUSED	Unused
15	12.0	DISIN-TEMP	Temperature during heat disinfect

Each of these values ranges from 0 to 255, with 255 representing the maximum voltage. Note that calibration further affects some values before they are displayed (except in diagnostics).

Conductivity is not an a-to-d channel, but is similar to one as far as the software is concerned. It is a 16-bit value which describes a frequency associated with the measured conductivity value.

WWD DUAL RECEIVER BOARD

The WWD Dual Receiver board is mounted on the inside of the rear card cage area occupying two of the “SPARE” connector ports. A ribbon cable from the board connects to P11 on the 190441 Functional board and P33 on the 190818 Functional board.

Note: On the 2008K@home, a 190441 Functional board is a programmed 190193 Functional board and a 190818 Functional board is a programmed 190649 Functional board.

SELECTOR SWITCH

On the WWD Dual Receiver board there is a DPST switch which allows connections to either a 190193 (190441) Functional board or to a 190649 (190818) Functional board (See picture below).

Note: If the switch is set correctly, the green indicator LED1 will illuminate. If incorrectly set, LED1 will be off. In either case, a built-in protection circuit prevents damage to the board if the switch is set incorrectly.

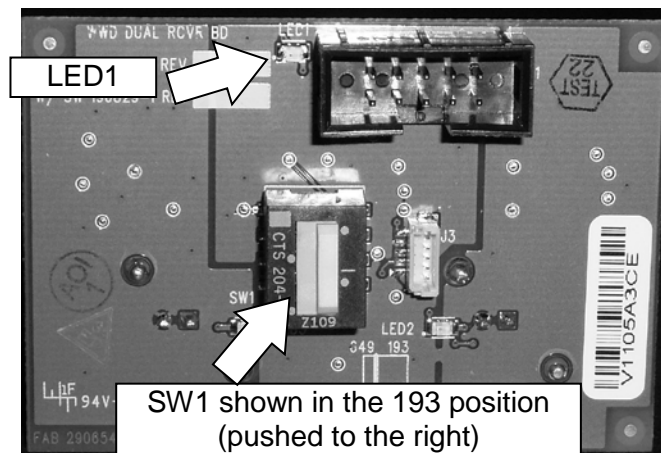

SECTION IV – MODULE DESCRIPTION

ARTERIAL BLOOD PUMP MODULE

The blood pump draws blood from the patient and pumps it to the dialyzer and back to the patient in a closed circuit. As the pump rotor rotates, twin rollers squeeze the pump segment, pulling and pushing the blood through the blood pump segment. The spring force of the twin rollers is designed in such a way, that the delivery pressure with the prescribed blood line system is limited, which rules out ruptures of the blood lines from kinking or clogging. In the cold state, i.e., in the preparation phase, the delivery pressure is even less and because of the bloodline tolerances, the pump may not self prime with air. The blood pump segment is held in place by a spring-loaded device located below the pump rotor. The pump rotor is removable for cleaning.

For reasons of personnel safety, the blood pump will run only when the door is closed. The speed of the pump can be adjusted using the arrow keys on the blood pump. The blood pump can be stopped by pressing the Start/Stop key or by opening the blood pump door. When the door is open, the diameter of the pump segment is shown in the display window.

The arterial pressure monitor port is located above the pump housing. Utilizing the arterial pressure port and a small air pump the arterial chamber level can be raised. By pressing the Level Adjust key, the air pump runs and removes air from the arterial chamber allowing the level to rise. Due to the risk of introducing air into the closed blood circuit, the air pump only removes air to raise the chamber level and cannot be used to lower it.

If it should become necessary, because of power failure or a line problem, the pump can be operated manually (in clockwise direction) with a separate hand crank attached to the rear panel of the machine.

The module is attached to the machine cabinet with two screws. The electrical connection to the card cage can be removed once the rear panel has been removed.

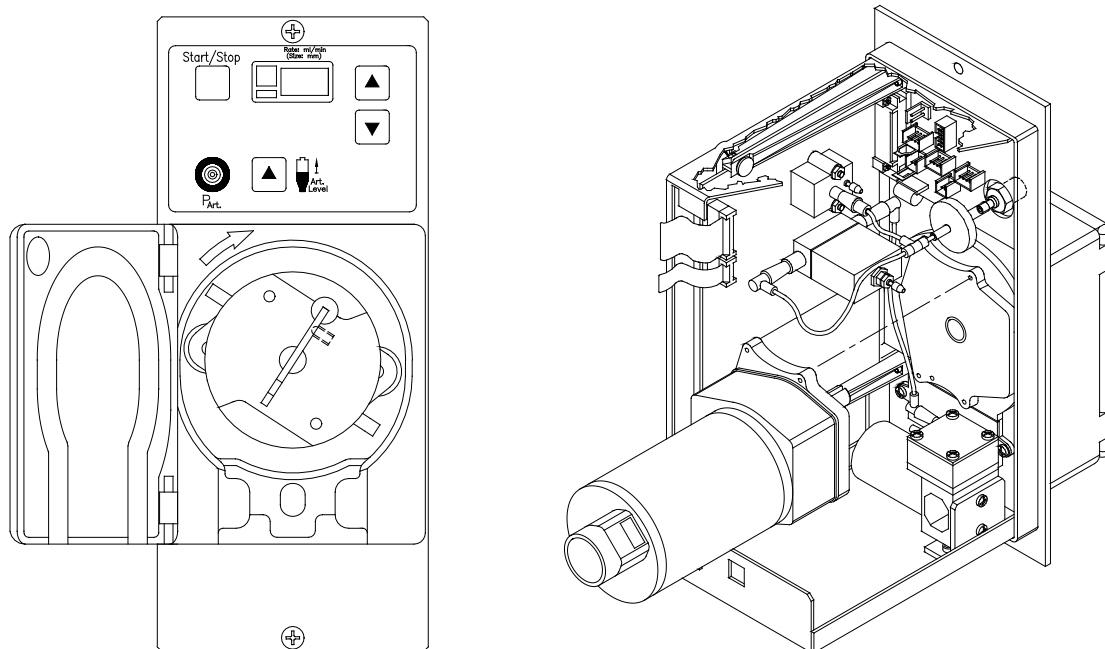

Blood Pump Operating and Indicating Elements

- Item 1: Delivery rate selectors (up and down keys).
Using the delivery rate selectors, the delivery rate of the pump can be set to between 20 ml/min and 600 ml/min depending on pump segment ID.
- Item 2: Blood pump segment tubing diameter selection.
The display of the segment diameter can be adjusted from 2.6, 4.8, 6.4 and 8.0mm (optional setting is 2 to 10 mm in 0.2 mm increments*).
The segment diameter is displayed when the door is opened.
- Item 3: Delivery rate display
3 digit LED display Resolution: 5 ml.
Red stoppage alarm display lights up if the rotor stops for 15 seconds (optional 30 seconds*) when blood pump is switched on.
- Item 4: Alarm and Error codes
A set of alarm codes (A.xx) and error codes (E.xx) will be displayed to inform the operator of a problem with the blood pump. A complete list of these codes along with cause and solution can be found on the next page.
- Item 5: Blood pump door.
Switches the blood pump off when opened.
- Item 6: Start/Stop key.
Starts and Stops the rotor when pressed.
- Item 7: Arterial Pressure port “P ART”
Luer lock.
- Item 8: Level Adjust key.
Raises the arterial chamber when pressed.

* Refer to the “Arterial Pressure Calibration” section of the 2008K@home Calibration Procedures (P/N 507664) for additional information regarding the blood pump dip-switch settings.



Note: Refer to the “Machine Specifications” section of the 2008K@home User’s Guide (P/N 490180) for the blood pressure module specifications.

Blood Pump Alarm & Error Codes

ALARM CODES

Below you will find the descriptions of Alarm Codes. Alarm Codes can be cleared by pressing the Reset keypad. If the Alarm Code returns, use the table below to resolve the alarm condition.

Alarm Code	Cause	Solution
A.11	Pump is not reaching speed.	Check or replace in the following order: <ul style="list-style-type: none"> • Rotor Hall Sensor • LP955 • LP956
A.13	Pump rotor is turning in the wrong direction.	Check or replace in the following order: <ul style="list-style-type: none"> • Rotor Hall Sensor • LP955 • LP956
A.16	Key stuck or held in too long.	Check or replace in the following order: <ul style="list-style-type: none"> • User holding key too long • BP Keypad • LP955 • LP956
A.20	Set speed-read back analog voltage at X348/14 is out of limits (set speed).	Check or replace LP955.
A.21	Actual speed-read back analog voltage at X348/10 is out of limits (actual speed).	Check or replace LP955.
A.22	Arterial pressure-read back analog voltage at X348/7 is out of limits.	Check or replace LP955.
A.24	Optical sensor frequency (tach) not in range.	Check or replace in the following order: <ul style="list-style-type: none"> • Motor/Tachometer Assy. • LP955 • LP956
A.25	Pressure increases too quickly when the Level Up key is pressed.	Check or replace in the following order: <ul style="list-style-type: none"> • Vent Valve • LP955

Alarm Code (cont.)	Cause	Solution
A.26	Pressure was adjusted too much in calibration mode.	Check or replace in the following order: <ul style="list-style-type: none"> • Pre/Post Pump set wrong • LP955
A.27	Timeout when receiving Intel-Hex-line or overflowed receive buffer.	Check or replace LP955.
A.28	Error in received Intel-Hex-line.	Check or replace LP955.
A.29	Pump rotor turning when it should not be (first revolution).	Check or replace in the following order: <ul style="list-style-type: none"> • Rotor Hall Sensor • LP955

ERROR CODES

Below you will find the descriptions of Error Codes. Error Codes can only be cleared by powering the machine off. Use the table below to resolve the error condition.

Error Code	Cause	Solution
E.01	EPROM CRC error.	Check or replace LP955.
E.02	Flash ROM CRC error.	Check or replace LP955.
E.03	RAM check error.	Check or replace LP955.
E.04	Reference Voltage error.	Check or replace LP955.
E.05	Serial EEPROM error.	Check or replace LP955.
E.06	Watchdog timeout.	Check or replace LP955.
E.07	+ 12 volts is outside the allowable range of 10.8 to 13.2 volts.	Check or replace in the following order: <ul style="list-style-type: none"> • Machine voltage (+12V) • 20 pin ribbon cable from machine • LP955
E.08	+ 24 volts is outside the allowable range of 22.8 to 28.0 volts.	Check or replace in the following order: <ul style="list-style-type: none"> • Machine voltage (+24V) • 20 pin ribbon cable from machine • LP955
E.09	- 12 volts is outside the allowable range of -9.6 to -13.2 volts.	Check or replace LP955.

Error Code (cont.)	Cause	Solution
E.10	+ 5 volts is outside the allowable range of 4.75 to 5.25 volts.	Check or replace LP955.
E.14	50 ms time period exceeded.	Check or replace LP955.
E.15	Software task was not completed correctly.	Check or replace LP955.
E.23	Pump rotor turning when it should not be (second revolution).	Check or replace in the following order: <ul style="list-style-type: none"> • Rotor Hall Sensor • LP955
E.97	Error copying data into Flash ROM.	Check or replace LP955.
E.98	Error erasing Flash ROM.	Check or replace LP955.
E.99	Transmit error during Flash update.	Check or replace LP955.

RED LED

The large red LED is next to the blood pump display. It will light if the door is open longer than the preset time of 15 or 30 seconds. This is set using dip-switch 4 on the LP955 board. The default setting is 30 seconds.

LED	Cause	Solution
RED LED LIT	Pump door is open longer than 30 seconds.	Check or replace in the following order: <ul style="list-style-type: none"> • Door Hall Sensor • LP955 • LP956



Note: Additional blood pump dip-switch settings can be found in the “Arterial Pressure Calibration” section of the 2008K@home Calibration Procedures booklet (P/N 507664).

LEVEL DETECTOR / VENOUS CLAMP MODULE

The module contains the holder for the venous drip chamber with air sensor, the connection for the venous return pressure and the venous clamp with optical blood/saline detector.

The venous drip chamber is pressed into the holder by the cover and is thereby slightly deformed. This is the only way to ensure proper function.



Warning! The venous drip chamber has to be calibrated for each drip chamber make and model. Make sure the filter in the drip chamber is below the sensor heads during the entire calibration procedure. Refer to the “Level Detector Calibration” section of the 2008K@home Calibration Procedures (P/N 507664) for the calibration process.

The venous drip chamber is connected via a filter to the pressure connection. The venous return pressure is indicated in the monitor.

The vent valve is located in the pressure line inside the plug-in module. The vent valve is controlled by the override automatic priming logic.

The venous clamp blocks off the extracorporeal circulation from the patient in the event of an alarm. The optical detector in the clamp holder detects blood in the tube system. Provided saline solution or air is present in the tube, the audible alarms may be suppressed depending upon the Audible Alarm Hardware Option setting in Service Mode.

The module is attached to the machine cabinet with two screws. The electrical connection to the card cage can be removed once the rear panel has been removed.

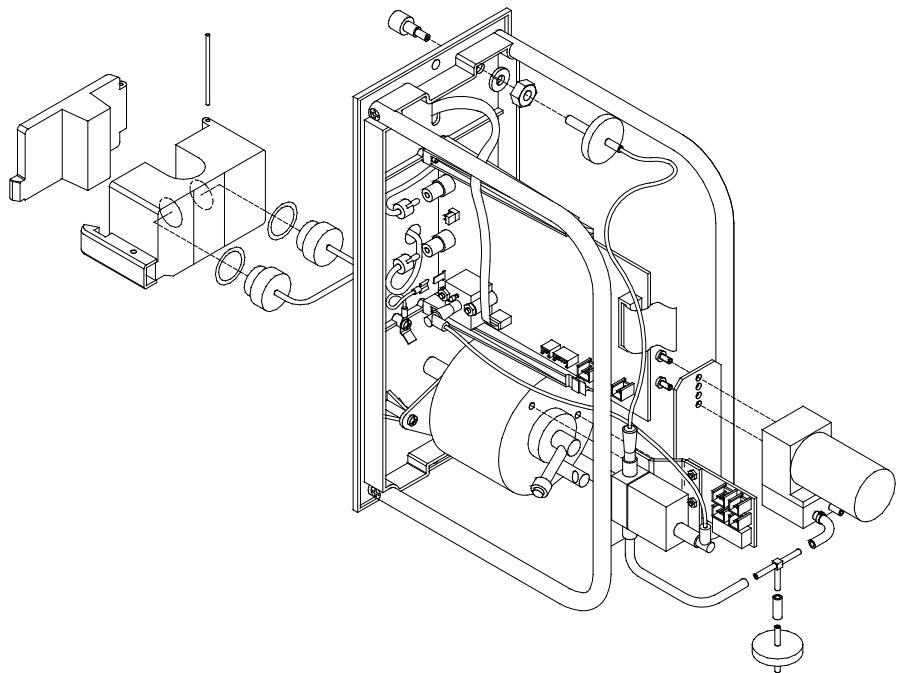
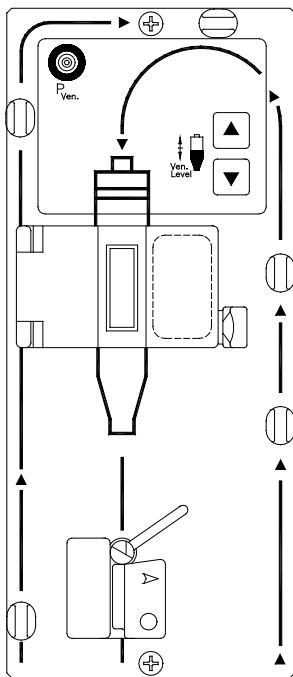

Note: Refer to the “Machine Specifications” section of the 2008K@home User’s Guide (P/N 490180) for the level detector specifications.

HEPARIN PUMP PLUG-IN MODULE

The heparin pump provides a means of injecting heparin into the blood circuit gradually over the course of the treatment or as a bolus. The pump works in conjunction with the Rx Parameter screen where the following parameters can be set:

- size and type of syringe
- stop time
- bolus amount*
- heparin rate

* Heparin Bolus Amount will only be visible if the Heparin Bolus is set to Yes in Treatment Options of Service Mode.

The module consists of a syringe holder and a carriage to push the syringe plunger at a metered rate.

The module is attached to the machine cabinet with two screws. The electrical connection to the card cage can be removed once the rear panel has been removed.

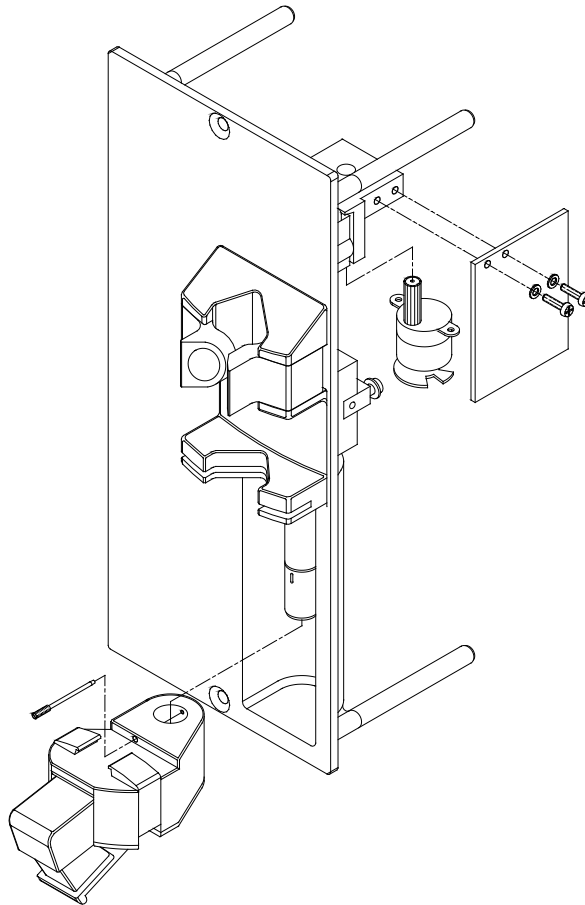

Note: Refer to the “Machine Specifications” section of the 2008K@home User’s Guide (P/N 490180) for the heparin pump specifications.

BLOOD PRESSURE MODULE

The blood pressure module utilizes an oscillometric method of obtaining an error free non-invasive blood pressure measurement. The module contains an inflation pump, pressure relief valve, pressure transducer and circuitry to measure systolic, diastolic pressures and heart rate (pulse rate). From the systolic and diastolic pressures the mean Arterial Pressure (MAP) can be calculated.

The blood pressure module works in conjunction with the Rx Parameter screen where the following parameters can be set:

Blood Pressure Alarm Limits

- Upper & Lower Systolic pressures
- Upper & Lower Diastolic pressures
- Upper & Lower Pulse rates

Blood Pressure Settings

- Inflation Pressure
- Interval between blood pressure readings

The module is attached to the machine cabinet with two screws and is located under the power supply. The electrical connection to the card cage can be removed once the rear panel has been removed. The blood pressure cuff tubing attaches directly to the module.

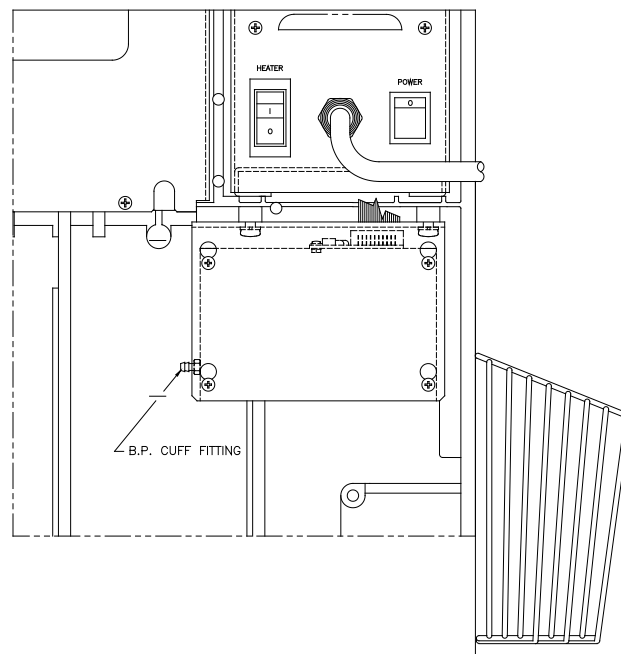

Note: Refer to the “Machine Specifications” section of the 2008K@home User’s Guide (P/N 490180) for the blood pressure module specifications.

Fresenius Medical Care North America

Manufactured by:
Fresenius USA, Inc.
4040 Nelson Avenue
Concord, CA 94520
800 227-2572